

## Scale-Pro™ Water Quality System



**Model Scale-Pro**  
Water Quality System

### Features

#### Easy Clear Scale-Pro Water Quality System

- Reduces lime scale formation from hard water in applications where water is either heated or evaporated.
- System extends the life and increases the efficiency of coffee brewers, espresso machines and steamers.
- Engineered force feeding orifice accurately controls feed rate without overdosing.
- Proprietary scale inhibitor does not break down at temperatures above 200°F (93.3°C).
- 3/4" NPT stainless steel connections easily adapt to most plumbing systems. (Kit 39000.0101 available with bushings to reduce to 3/8" and 1/4" NPT).
- Working flow rate of 6 gpm (22 lpm) accommodates most high temperature foodservice equipment.
- FDA-CFR and NSF compliant materials.
- Recommended for use in combination with an EQHP10, 25, 54 (non-L) system.
- System maximum operating pressure is 125 psi (862 kPa) and operating temperature 100°F (38°C).
- Suggested cartridge change-out is every 6 months.

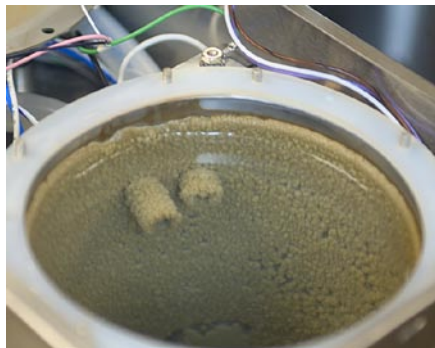

Water tank without Scale-Pro in use.\*



Water tank with Scale-Pro in use.\*

\*Performance measured under controlled conditions, individual results will vary based on geographic region and water quality. Test conducted during 3 month period and 2900 brew cycles with two new BUNN CDBCW brewers with water hardness equalling 28-30 grains. Scale-Pro is a scale inhibitor designed to reduce lime scale build-up and will not remove existing lime.

For current specification sheets and other information, go to [www.bunn.com](http://www.bunn.com).

### Related Products

**Replacement Cartridge**  
Scale-Pro CRTG  
Product No.: 39000.1010

**Scale-Pro Installation Kit**  
Product No.: 39000.0101

Model	Agency Listing
Scale-Pro	

## Dimensions & Specifications

Model	Product #	Service Flow Rate and Capacity
39000.0010	Scale-Pro	Up to 6 gpm

*Note: Inlet and outlet plumbing connections are 3/4" horizontal NPT.  
Kit 39000.0101 available with bushings to reduce to 3/8" and 1/4" NPT.*

Do not use with water that is microbiologically unsafe or of unknown quality without adequate disinfection before or after the system.

BUNN recommends regularly scheduled maintenance and replacement of the filter cartridge(s) in order for the product to perform as advertised/sold. Change the filter cartridge at least every 6 months. BUNN shall not be liable for system failures due to improper maintenance.

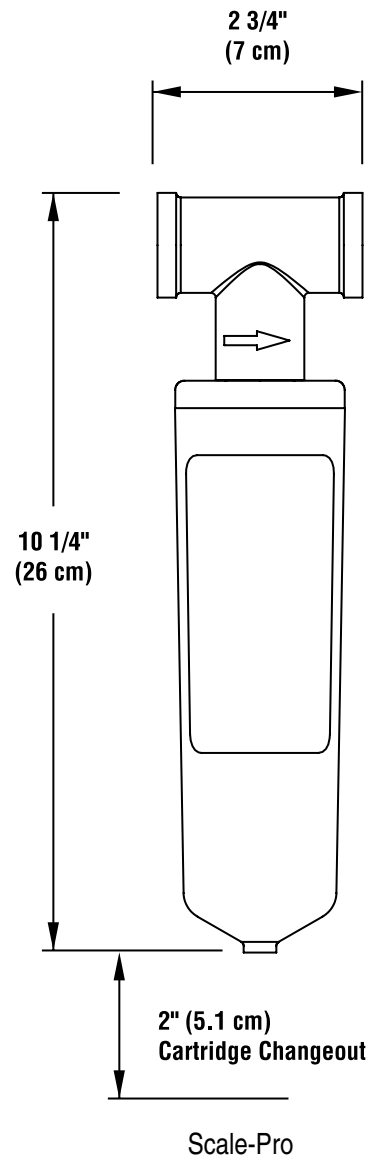
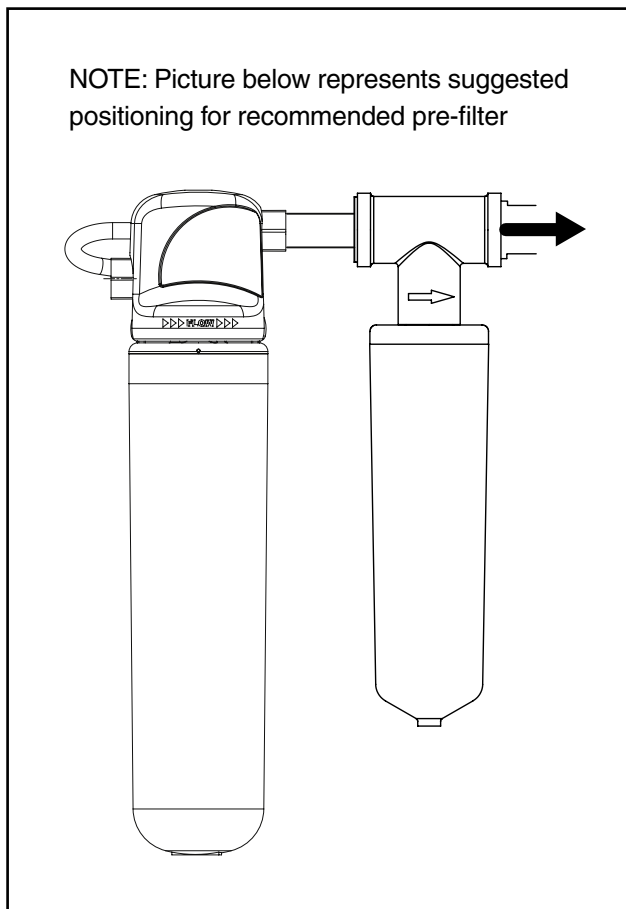

BUNN Corporation - 1400 Stevenson Drive Springfield, Illinois 62703 • 800-637-8606 • 217-529-6601 • Fax 217-529-6644 • www.bunn.com

BUNN® practices continuous product research and improvement. We reserve the right to change specifications and product design without notice. Such revisions do not entitle the buyer to corresponding changes, improvements, additions or replacements for previously purchased equipment.

All dimensions shown in inches. Bunn Corporation owns all copyrights relating to materials in this publication. Please contact Bunn Corporation to request permission to reproduce any portion of this publication.