

## Tea Concentrate Dispenser

### Features

#### Tea Concentrate Dispenser

- Venturi valve creates siphon pulling product through to mixing valve.
- Rear shut-off valve for cleaning dispenser.
- Accommodates up to two, 1 gallon (3.8 L) jugs in top of container, or bag-in-box.
- Side off-set handles for side-by-side placement.
- Built-in pressure regulator provides consistent product to water ratio.
- Mixes a range of 5:1 to 15:1 concentrate to water ratio.
- Solid plastic lid.



#### TCD-1

Dimensions: 22.25" H x 12.8" W x 18.2" D  
(56.5cm H x 32.5cm W x 46.23cm D)

#### TCD-2

Dimensions: 22.25" H x 12.8" W x 18.89" D  
(58.5cm H x 32.5cm W x 48cm D)



Bottom View



Top View

For current specification sheets and other information, go to [www.bunn.com](http://www.bunn.com).

### Related Products

#### TDO Lid Retainer

Product No. : 35136.0001



#### Drip Tray

Product No. : 38029.1000

Product No. : 38029.1001 (for use with TCD  
Booster Stand)



#### TCD Booster Stand

Product No. : 38839.0000



#### Model

#### Agency Listing

TCD-1



TCD-2



# Dimensions & Specifications

**Model      Product #      Cubic Measure      Shipping Weight**

TCD-1	37750.0000	4.25 ft <sup>3</sup>	17.1 lbs.
TCD-2	37750.0002	4.25 ft <sup>3</sup>	19.6 lbs.

Electrical: No electrical

Plumbing: 30-90 psi (207-621 kPa). Unit requires a 1gpm (3.79L per minute) line flow capacity. Model supplied with a 1/4" male flare fitting. Shut-off valve.

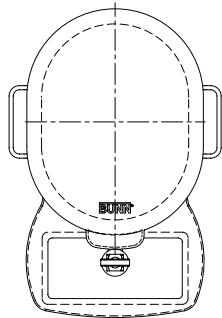

TCD-1

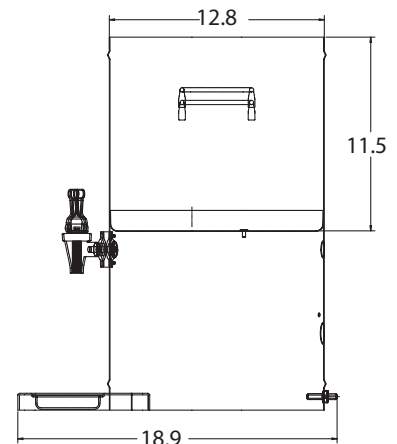
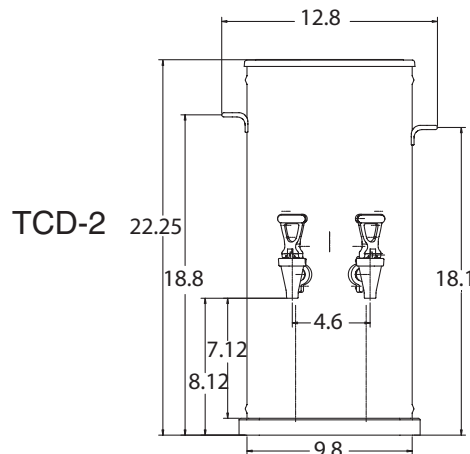
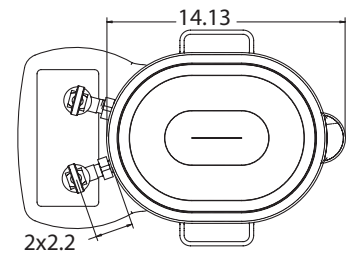
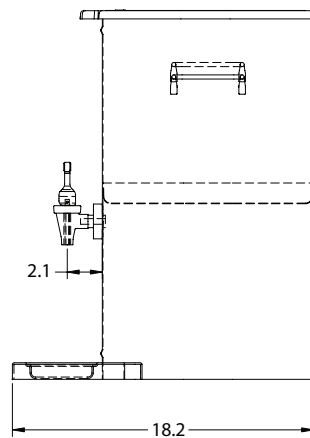
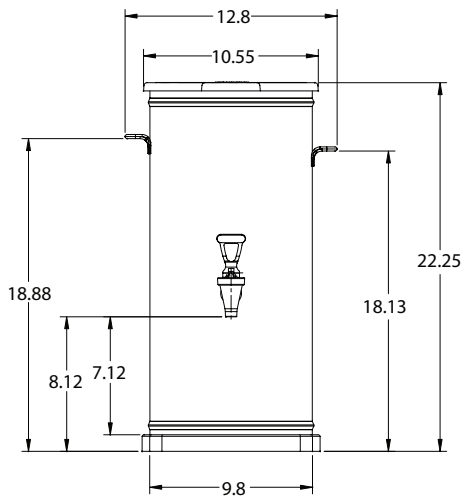

Bunn-O-Matic® Corporation - 1400 Stevenson Drive Springfield, Illinois 62703 • 800-637-8606 • 217-529-6601 • Fax 217-529-6644 • www.bunn.com

BUNN® practices continuous product research and improvement. We reserve the right to change specifications and product design without notice. Such revisions do not entitle the buyer to corresponding changes, improvements, additions or replacements for previously purchased equipment.

All dimensions shown in inches.