

BUNN®

Soft Heat® *Server* 1.75 Gallon

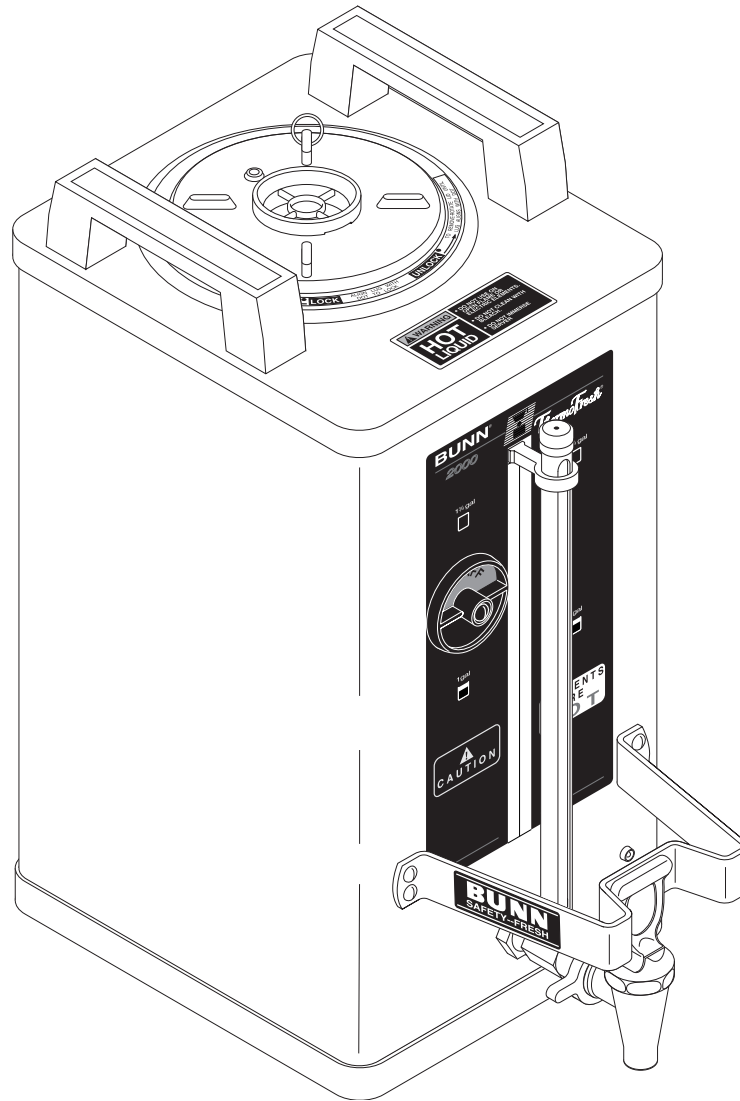

INSTALLATION & OPERATING MANUAL

BUNN-O-MATIC CORPORATION

POST OFFICE BOX 3227

SPRINGFIELD, ILLINOIS 62708-3227

PHONE: (217) 529-6601 FAX: (217) 529-6644

To ensure you have the latest revision of the manual or to obtain the illustrated parts catalog, please visit the Bunn-O-Matic website, at www.bunn.com. This is absolutely FREE, and the quickest way to obtain the latest catalog and manual updates. Contact Bunn-O-Matic Corporation at 1-800-286-6070 to obtain a paper copy of the required Illustrated Parts Catalog mailed via U.S. Postal Service.

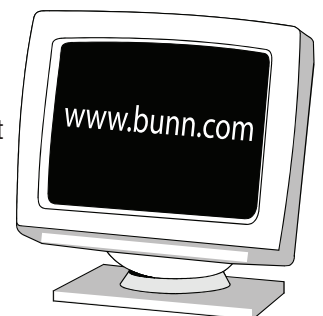

INTRODUCTION

This server allows portable storage and dispensing of up to 1 $\frac{3}{4}$ gallons of hot beverage at remote locations. Coffee can be brewed directly into the server without removing the cover when used with a BUNN® Dual® SH or Single® SH coffee brewer. The spill-resistant design lessens the chance of hot beverage burns and splashes.

BUNN-O-MATIC COMMERCIAL PRODUCT WARRANTY

Bunn-O-Matic Corp. ("BUNN") warrants equipment manufactured by it as follows:

- 1) All equipment other than as specified below: 2 years parts and 1 year labor.
- 2) Electronic circuit and/or control boards: parts and labor for 3 years.
- 3) Compressors on refrigeration equipment: 5 years parts and 1 year labor.
- 4) Grinding burrs on coffee grinding equipment to grind coffee to meet original factory screen sieve analysis: parts and labor for 3 years or 30,000 pounds of coffee, whichever comes first.

These warranty periods run from the date of installation BUNN warrants that the equipment manufactured by it will be commercially free of defects in material and workmanship existing at the time of manufacture and appearing within the applicable warranty period. This warranty does not apply to any equipment, component or part that was not manufactured by BUNN or that, in BUNN's judgment, has been affected by misuse, neglect, alteration, improper installation or operation, improper maintenance or repair, damage or casualty. This warranty is conditioned on the Buyer 1) giving BUNN prompt notice of any claim to be made under this warranty by telephone at (217) 529-6601 or by writing to Post Office Box 3227, Springfield, Illinois 62708-3227; 2) if requested by BUNN, shipping the defective equipment prepaid to an authorized BUNN service location; and 3) receiving prior authorization from BUNN that the defective equipment is under warranty.

THE FOREGOING WARRANTY IS EXCLUSIVE AND IS IN LIEU OF ANY OTHER WARRANTY, WRITTEN OR ORAL, EXPRESS OR IMPLIED, INCLUDING, BUT NOT LIMITED TO, ANY IMPLIED WARRANTY OF EITHER MERCHANTABILITY OR FITNESS FOR A PARTICULAR PURPOSE. The agents, dealers or employees of BUNN are not authorized to make modifications to this warranty or to make additional warranties that are binding on BUNN. Accordingly, statements by such individuals, whether oral or written, do not constitute warranties and should not be relied upon.

If BUNN determines in its sole discretion that the equipment does not conform to the warranty, BUNN, at its exclusive option while the equipment is under warranty, shall either 1) provide at no charge replacement parts and/or labor (during the applicable parts and labor warranty periods specified above) to repair the defective components, provided that this repair is done by a BUNN Authorized Service Representative; or 2) shall replace the equipment or refund the purchase price for the equipment.

THE BUYER'S REMEDY AGAINST BUNN FOR THE BREACH OF ANY OBLIGATION ARISING OUT OF THE SALE OF THIS EQUIPMENT, WHETHER DERIVED FROM WARRANTY OR OTHERWISE, SHALL BE LIMITED, AT BUNN'S SOLE OPTION AS SPECIFIED HEREIN, TO REPAIR, REPLACEMENT OR REFUND.

In no event shall BUNN be liable for any other damage or loss, including, but not limited to, lost profits, lost sales, loss of use of equipment, claims of Buyer's customers, cost of capital, cost of down time, cost of substitute equipment, facilities or services, or any other special, incidental or consequential damages.

BrewWISE, BUNN Gourmet Ice, BUNN Pour-O-Matic, BUNN, Bunn-OMatic, Bunn-O-Matic, BUNNlink, BUNNserve, BUNN Espresso, DBC, Dr. Brew, Dual, EasyClear, EasyGard, Easy Pour, FlavorGard, Gourmet Ice, Gourmet Juice, High Intensity, IMIX, Infusion Series, Legendary for Quality, The Mark of Quality in Beverage Equipment Worldwide, My Café, Power-Logic, Safety-Fresh, Scale-Pro, Single, Smart Funnel, Smart Hopper, Soft Heat, SplashGard, System III, ThermoFresh, 392, AXIOM, Beverage Profit Calculator, Beverage Bar Creator, BrewLOGIC, BrewMETER, BrewWIZARD, BUNNSERVE, BUNNsource, Coffee At Its Best, Cool Froth, Digital Brewer Control, Intellisteam, Nothing Brews Like a BUNN, Pouring Profits, Pulse Wave, Quality Beverage Equipment Worldwide, Signature Series, Silver Series, Smart Heat, SmartWAVE, Tea At Its Best, The Horizontal Red Line, Titan, Ultra, are either trademarks or registered trademarks of Bunn-O-Matic Corporation.

USER NOTICES

The notices on this server should be kept in good condition. Replace unreadable or damaged labels.



#26186.0000

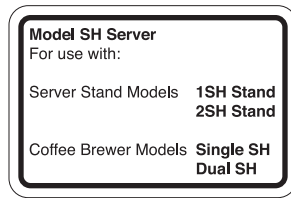

#28056.0000



#28151.0000

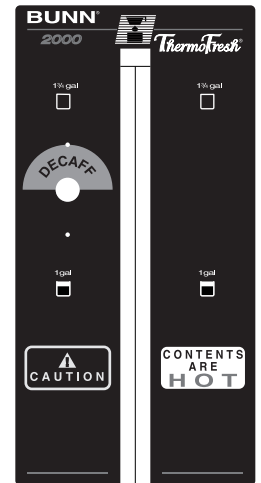

#26178.0001

USING THE SERVER

Simply select the desired brew batch size with the rotary switch on the brewer and place the server beneath the funnel dripout. One half, one, or one and three-quarter gallon batches may be brewed into the 1 $\frac{3}{4}$ gallon server. Press and release the START switch to initiate a brew cycle. Place the decaffeinated coffee indicator in the proper position for the type of coffee being brewed. Fresh HOT coffee is immediately available at the faucet.

NOTE – Be careful not to overfill the server.

The power indicator will remain on for thirty minutes from power up then begin to flash. The flashing indicator alerts the operator that the product is thirty minutes old and should be replaced per McDonald's Corporate policy.

CLEANING

NOTE - Bunn-O-Matic recommends CASCADE® dishwashing detergent for thorough cleaning. DO NOT use bleach. CASCADE® is a registered trademark of Procter & Gamble Co., Cincinnati, Ohio.

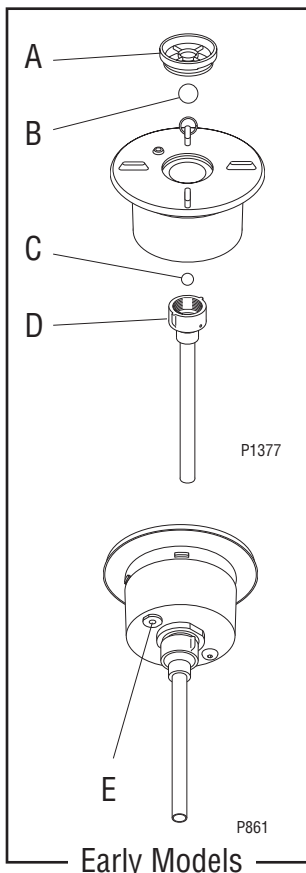

Early Models

1. Turn the entire lid assembly one-quarter turn counterclockwise to remove it for daily dishwasher cleaning.
2. Remove retainer cap (A), (ball (B) early models only), the inlet tube assy (D) and (ball (C) early models only) from the lid for cleaning. They are removed by unscrewing in a counterclockwise direction.
3. Clean the airvent (E) on the bottom of the lid assembly with the supplied brush (#26367.0000) (Early models only).
4. After cleaning, reassemble the lid assembly, being careful to reinstall all parts removed.
5. Disassemble the faucet for thorough cleaning. Clean the faucet shank with the supplied brush (#00674.0000).
6. Clean the sight gage with the supplied brush (#26367.0000).
7. Clean all other surfaces with a damp cloth rinsed in any mild, non-abrasive, liquid detergent.
8. Thoroughly rinse the entire server after cleaning.
9. Fill with brew temperature water and leave full overnight.

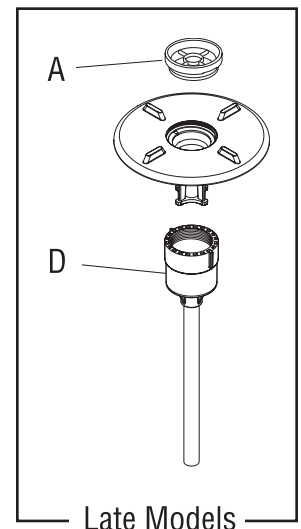

Late Models

NOTE - Empty the water from the server before brewing.

SCHEMATIC WIRING DIAGRAM FOR SH SERVER

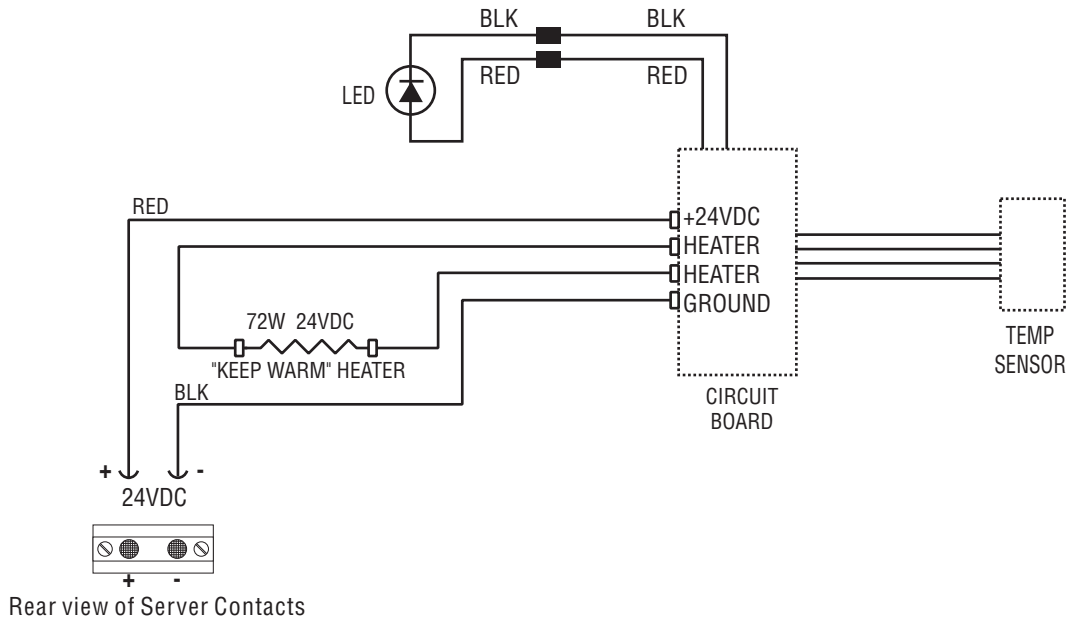

24 VOLTS DC